

1 SPECIFICATION



1.1 DESCRIPTION

- Halogen Free
 - 125°C maximum total temperature operation
 - 2.7 x 2.2 x 1.2mm maximum surface mount package
 - Powder alloy core material
 - Magnetically shielded, low EMI
 - High current carrying capacity, Low core losses
 - RoHS compliant

1.4 Product Identification

CCHB-252012-1R0-M

(1) (2) (3) (4)

(1) Product Series

(2) Choke Size

(3) Initial Inductance(L @ 0A):1R0=1.0 μ H

(4) Inductance Tolerance:M=L \pm 20%

1.2 APPLICATIONS

- Voltage Regulator Module (VRM)
- Multi-phase regulators
- Point-of-load modules
- Smart phone POL modules
- SSD modules
- Notebook regulators
- Battery power systems
- Graphics cards
- Data networking and storage systems

1.3 ENVIRONMENTAL DATA

- Storage temperature range: -55°C to +125 °C
- Operating temperature range: -55°C to +125°C
(ambient plus self-temperature rise)
- Solder reflow temperature: J-STD-020D compliant

1.5 ELECTRICAL PARAMETERS

Part Number	L0	I _{DC}	I _{DC}	I _{SAT}	I _{SAT}	DCR	DCR
	(μ H) \pm 20%	(Amp) Max.	(Amp) Typ.	(Amp) Max.	(Amp) Typ.	Typ. (m Ω) @25 $^{\circ}$ C	Max. (m Ω) @25 $^{\circ}$ C
CCHB-252012-R24-M	0.24	6.5	7.0	9.0	9.5	11.0	15.0
CCHB-252012-R33-M	0.33	6.0	6.5	7.0	7.5	12.0	19.0
CCHB-252012-R47-M	0.47	5.5	6.1	6.2	6.7	17.0	23.0
CCHB-252012-R68-M	0.68	5.0	5.5	5.5	6.0	29.0	35.0
CCHB-252012-1R0-M	1.0	3.8	4.2	4.5	5.0	36.0	44.0
CCHB-252012-1R5-M	1.5	3.2	3.5	3.2	4.3	64.0	77.0
CCHB-252012-2R2-M	2.2	2.3	2.7	3.0	3.5	73.0	87.0
CCHB-252012-3R3-M	3.3	1.8	2.1	2.5	3.0	110.0	135.0
CCHB-252012-4R7-M	4.7	1.5	1.8	2.0	2.5	196.0	235.0

Notes:

1. Initial Inductance (L0) Test Parameters: 1MHz, 1V, I_{DC}=0.0A, +25 $^{\circ}$ C
2. Operating temperature range - 55 $^{\circ}$ C to + 125 $^{\circ}$ C
3. I_{DC}(A): DC current (A) that will cause an approximate Δ T of 40 $^{\circ}$ C
4. I_{SAT}(A): DC current (A) that will cause L0 to drop approximately 30 %
5. The part temperature (ambient + temp rise) should not exceed 125 $^{\circ}$ C under worst case operating conditions. Circuit design, component placement, PWB trace size and thickness, airflow and other cooling provisions all affect the part temperature. Part temperature should be verified in the end application.

■ 1.6 MATERIAL

■ Schematics

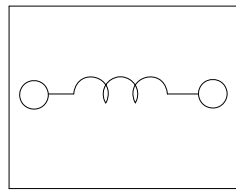
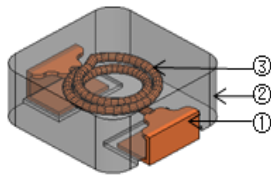

LIST

NO.	Part Name	Material	
1	Electrode	Cu+Sn plating C1100R, Sn:Min.8μm	0.24-10.0μH
2	Core	Metal composite core	
3	Coil	Copper wire, 200°C	

1.7 MECHANICAL PARAMETERS

1.8 RECOMMENDED PCB LAYOUT

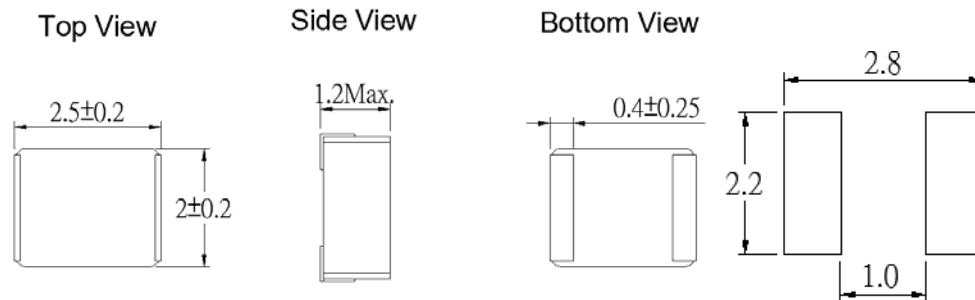

(unit:mm)

Notes:

1. Tolerances are +/-0.1 millimeters unless stated otherwise
2. Dimensions of recommended PCB layout are reference only.
3. Do not route traces nor place vias underneath the inductor. Proper layout is required.

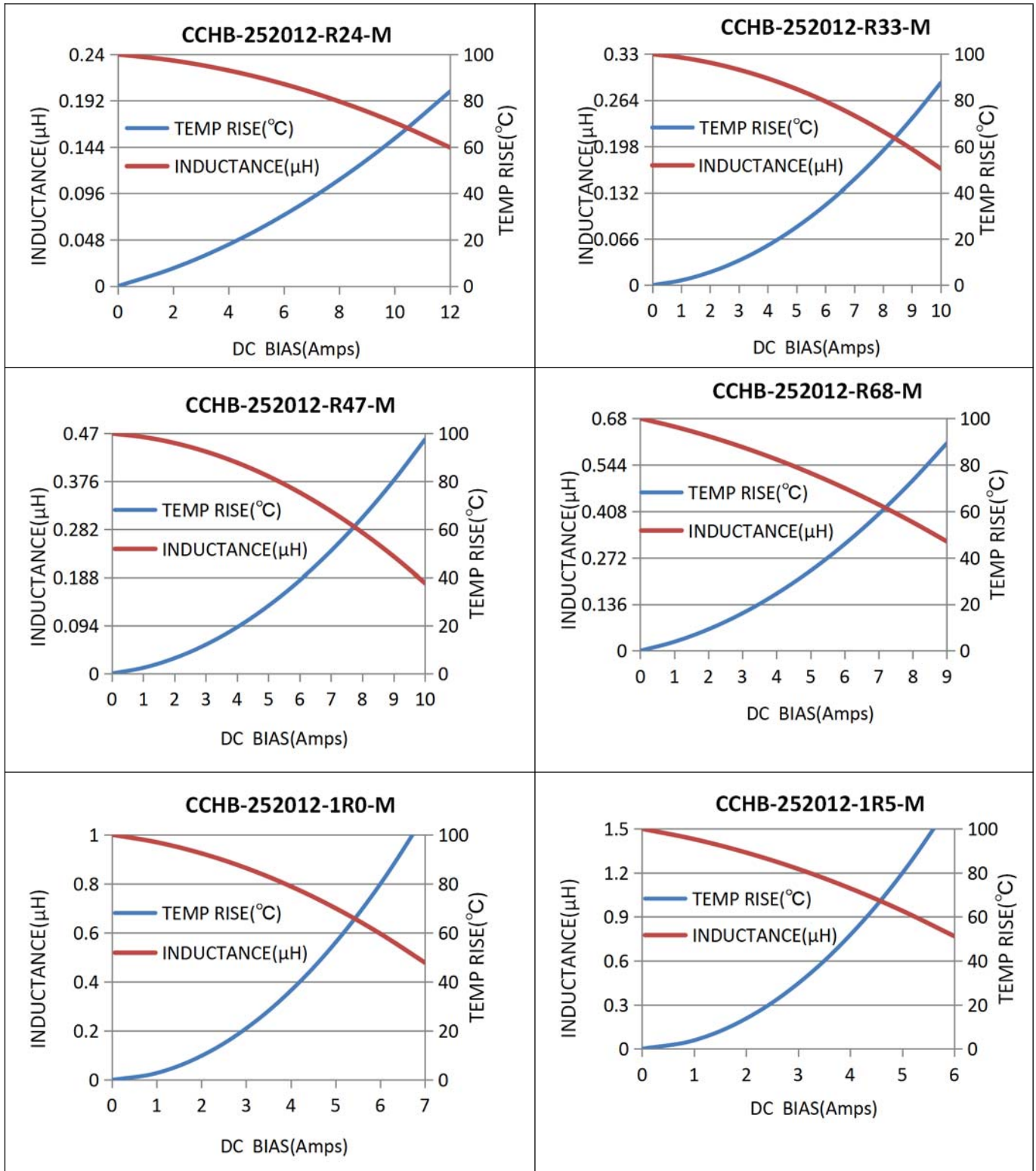
2 INDUCTANCE & TEMPERATURE RISE VS IDC

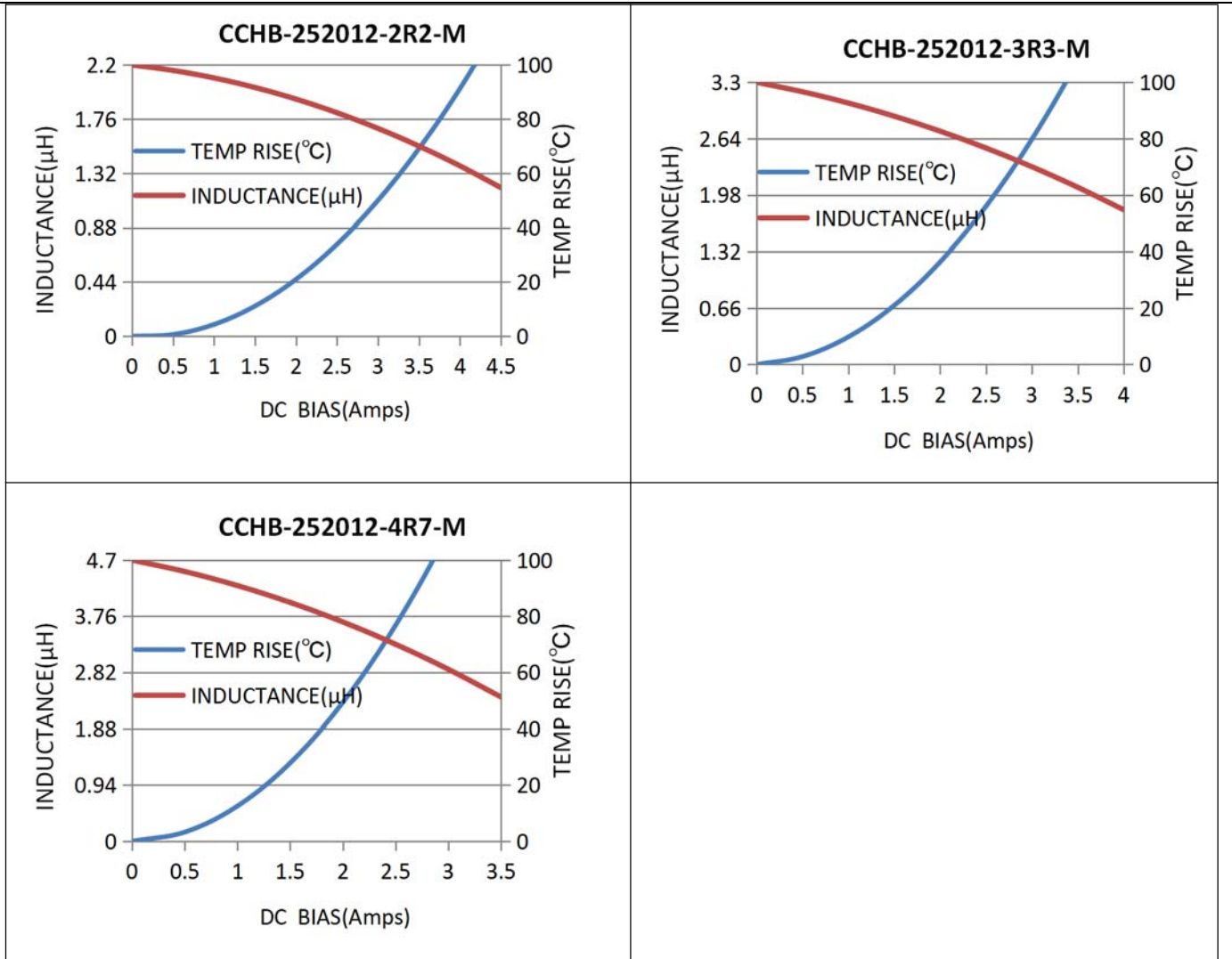

3 REFLOW PROFILE

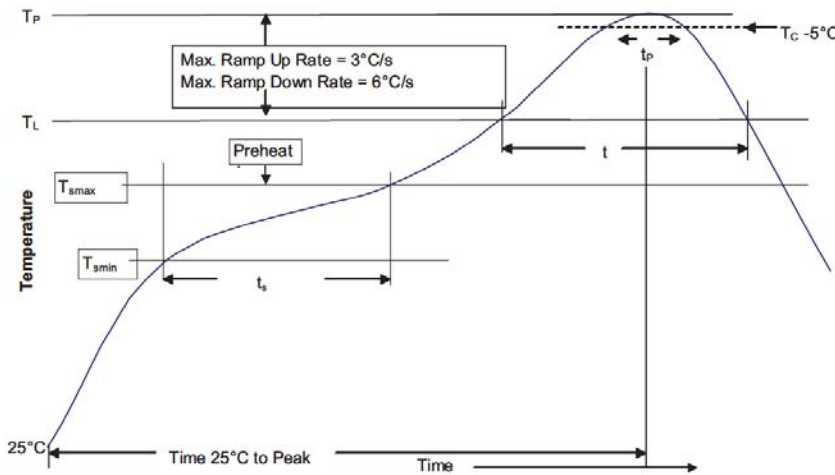

Table 1 - Standard SnPb Solder (T_C)

Package Thickness	Volume mm ³ <350	Volume mm ³ ≥350
<2.5mm	235°C	220°C
≥2.5mm	220°C	220°C

Table 2 - Lead (Pb) Free Solder (T_C)

Package Thickness	Volume mm ³ <350	Volume mm ³ 350 - 2000	Volume mm ³ >2000
<1.6mm	260°C	260°C	260°C
1.6 - 2.5mm	260°C	250°C	245°C
>2.5mm	250°C	245°C	245°C

Reference JDEC J-STD-020

Profile Feature	Standard SnPb Solder	Lead (Pb) Free Solder
Preheat and Soak		
• Temperature min. (T_{smin})	100°C	150°C
• Temperature max. (T_{smax})	150°C	200°C
• Time (T_{smin} to T_{smax}) (t_s)	60-120 Seconds	60-120 Seconds
Average ramp up rate T_{smax} to T_p	3°C/ Second Max.	3°C/ Second Max.
Liquidous temperature (T_L)	183°C	217°C
Time at liquidous (t_L)	60-150 Seconds	60-150 Seconds
Peak package body temperature (T_p)*	Table 1	Table 2
Time (t_p)** within 5 °C of the specified classification temperature (T_C)	20 Seconds**	30 Seconds**
Average ramp-down rate (T_p to T_{smax})	6°C/ Second Max.	6°C/ Second Max.
Time 25°C to Peak Temperature	6 Minutes Max.	8 Minutes Max.

* Tolerance for peak profile temperature (T_p) is defined as a supplier minimum and a user maximum.

** Tolerance for time at peak profile temperature (t_p) is defined as a supplier minimum and a user maximum.

4 PACKAGE INFORMATION-mm

Peel-off Force

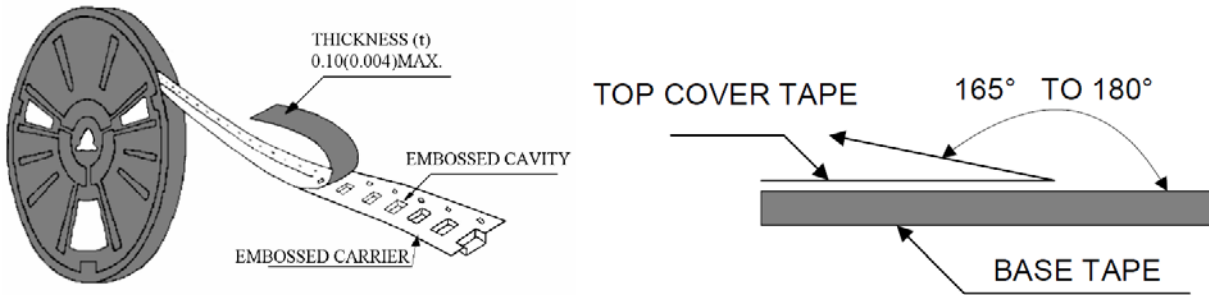

The force for peeling off cover tape is 10 to 70 grams in the arrow direction.

4.1 Tape Packaging Dimensions

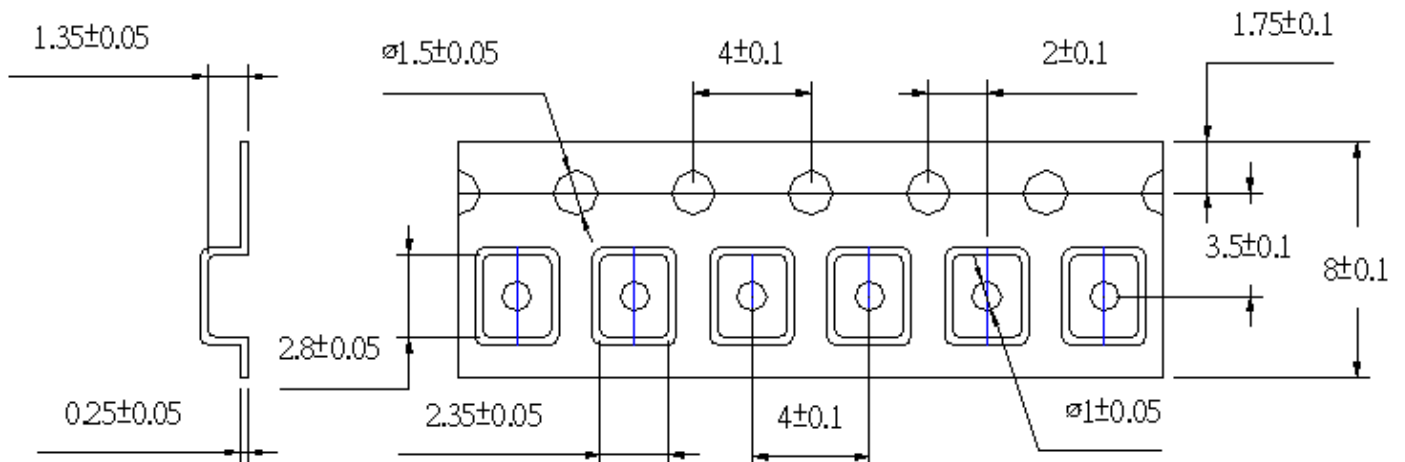

Taping dimension and tape direction, Leader ,Trailer, section dimension

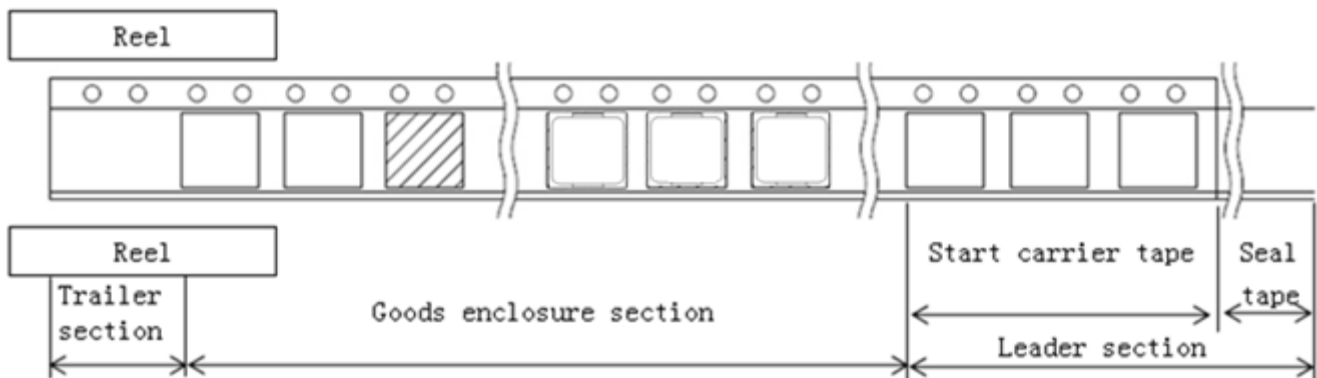

Leader section	Min.400mm
Carrier tape start size	Min.100mm
Trailer section size	Min.160mm

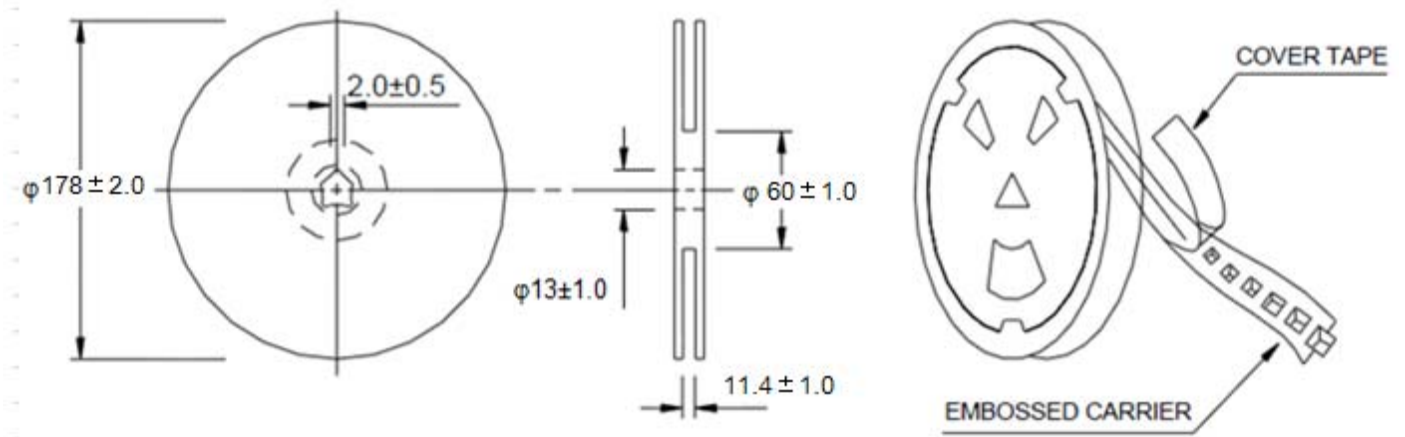
4.2 Reel Dimensions**4.3 Taping Quantity**

3000pieces/Reel,

4.4 Carton

Pizza packaging: 1Reel/ Pizza Box

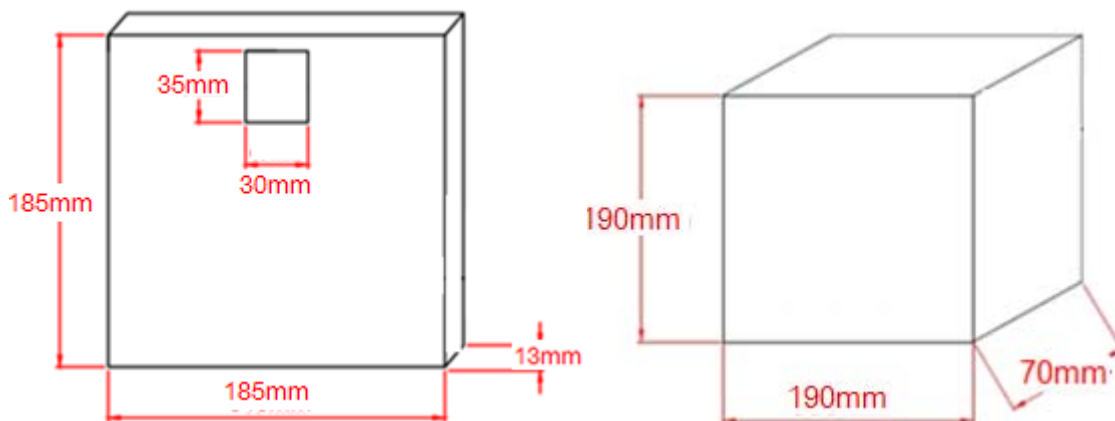

External Packaging :5 Boxes/Carton